

Technical BULLETIN

© 2002 YAMAHA MOTOR CORPORATION, U.S.A.

2003 RX-1 (RX10H, SH, RH, RSH, MH, MSH) Predelivery Setup Service Tips



INTRODUCTION

The new technology of the RX-1 requires several different procedures as part of the predelivery setup (refer to the RX-1 Assembly Manual (LIT-12668-02-28) when performing the Predelivery Inspection (PDI)).

Following are several additional service tips to help you properly assemble and deliver a new RX-1.

ASSEMBLY

The following items are additions or corrections to the RX-1 Assembly Manual:

CAUTION:

Do not use the front bumper to lift the snowmobile for an extended period of time (e.g., for ski or shock installation). The bumper can be used to temporarily lift or move the snowmobile, but do not support the weight of the machine for long periods of time.

Page 2-1, 2-2:

During installation of the headlight trim piece, take care not to scratch the shroud with the spring nuts (see adjacent illustration).

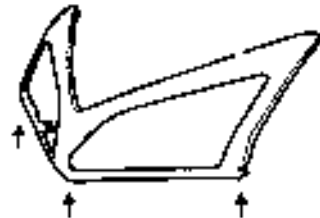

TAKE CARE NOT TO SCRATCH THE SHROUD WITH THE SPRING NUTS DURING INSTALLATION

Page 2-4:

Install the front upper shock mount washers, ③, on the sides of the shock (see Illustration below). The illustration in the manual incorrectly shows the washers installed next to the mounting bolts and nuts.

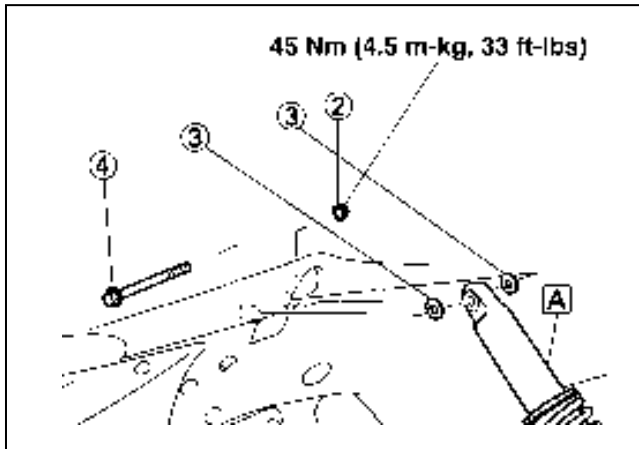

Page 2-10 and 2-11:

The two pieces of 25 x 35mm heat reflective tape are installed on the bottom surface of the rear bumper plastic cover. Install the tape so the forward edge wraps up and around the tabs (see Illustration below).

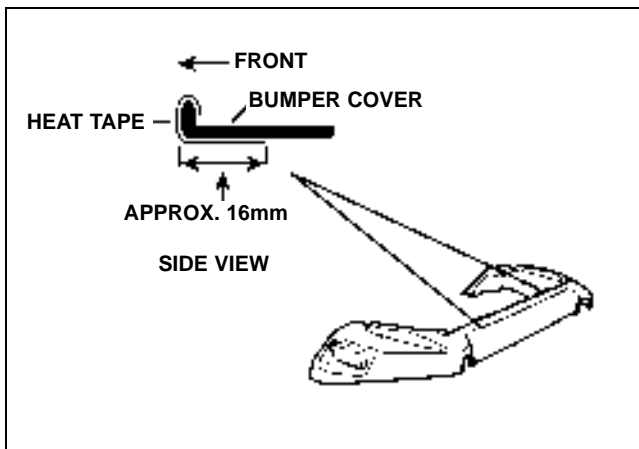

MAINTENANCE-FREE BATTERY INITIAL SERVICE

The 2003 RX-1 uses a Yuasa Maintenance-free Battery that requires special filling and charging procedures when first serviced. Follow these important steps to ensure maximum output and life. Do not be tempted to take shortcuts. A battery that fails prematurely will cause customer dissatisfaction.

- Make sure the battery fills completely with electrolyte. This can take 20 - 30 minutes.
- Don't squeeze the fluid pack or punch "vent" holes in it for faster filling. It will cause the cells to fill unevenly and shorten battery life.
- After filling, let the battery sit for an additional 30 minutes to fully absorb the electrolyte.
- Charge the battery to 13.0 volts using a battery charger designed for maintenance-free batteries. This can take up to 24 hours.
- Leave the sealing cap strip off during initial charging.
- Do not install a partially charged battery and assume the snowmobile's charging system will finish the charging process. The charging system is not capable of completing the initial charge process, and will result in permanently reducing the maximum output of the battery.
- **Install a "battery tender" type maintenance-free battery charger that allows quick connection and easy charging during storage.** After the initial service, this is the single most important thing you can do to ensure your customer's RX-1 will start every time the key is turned. See below for battery charger information and recommendations.

Optimate III Battery Charger

Since it is possible the snowmobile will not be operated for an extended length of time between uses, Yamaha recommends adding a quick-connect charger system designed for maintenance-free batteries. The Optimate III Battery Charger, available through Yamaha (P/N ACC-OPTIM-AT-E3), is an excellent charger of this type. It offers the following features that will benefit both the dealer and the customer:

- Charger leads connect permanently to the battery and use a quick-connect feature. Just raise the hood and plug in.
- “Smart Charger” feature means it can be left connected indefinitely, it will automatically switch to “maintenance” charging mode when full charge is reached.
- Capable of sensing and “recovering” deeply discharged maintenance free batteries.
- \$52.60 suggested retail price. Less than the cost of a replacement battery!



ENGINE OIL INFORMATION

The RX-1 snowmobile is shipped from the factory with engine oil in the engine and oil tank. The oil does not need to be changed during predelivery (PDI), the unit can be delivered and operated for the first 500 miles using the factory oil.

Checking Oil Level

The RX-1 uses a dry sump oil system. The oil level is checked at the oil tank, using the oil level gauge/dipstick. During PDI, check the oil level by performing the following steps:

1. With the snowmobile on a level surface, start the engine and idle it for several minutes or until the floorboard heat exchangers start to warm. **For proper break-in, it's important that the engine does not exceed idle rpm for the first 15 minutes of operation (see Engine Break-in Procedure).** During this time, some exhaust smoke may occur as the engine breaks in, and as residual oil is burned out of the exhaust system.
2. After warming, turn the engine off, disconnect the oil level gauge connector and remove the oil level gauge/dipstick. Wipe the oil level gauge/dipstick clean and reinsert it into the oil filler hole without threading it in, and remove it again to check the oil level. The oil level should be between the “F” and “E” marks.
3. Add oil of the proper type (see below) only if the level is below the “E” mark. If adding oil, do not fill above the “F” mark.
4. Reinstall the oil level gauge/dipstick, tighten and install the oil level gauge connector.

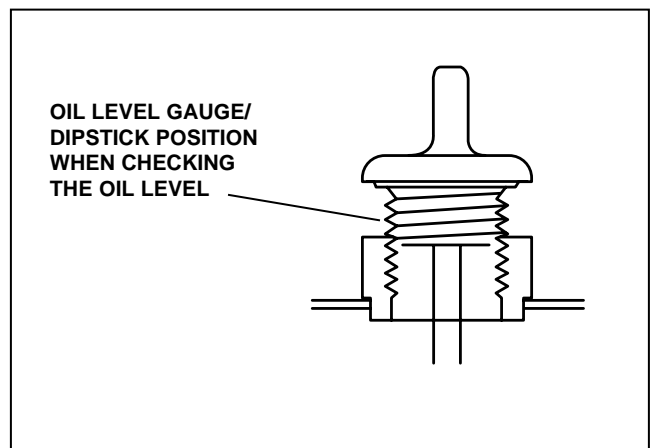
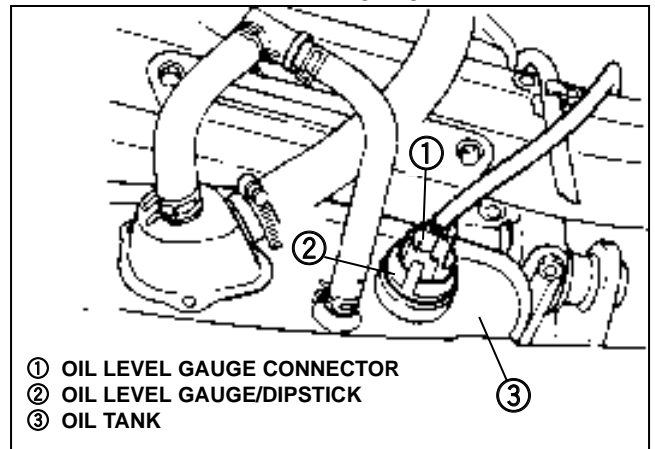

NOTE: Do not thread in the oil level gauge/dipstick when checking the oil level.

Oil and Filter Scheduled Maintenance

Service Procedure	Initial 500 Miles (800 km)	Every Season or 2,000 Miles (3,200 km)	Every 12,000 Miles (20,000 km)
Oil Change	•	•	
Oil Filter Change	•		•

Use Yamalube® 4-Stroke Engine Oil, Cold Weather Formula (P/N: ACC-Y4CW5-30-12) or equivalent.

IMPORTANT: Use only 4-stroke engine oil, SAE 5W-30, SE rated or higher. Do not use oils labeled ENERGY CONSERVING or ENERGY CONSERVING II.

ENGINE BREAK-IN PROCEDURE

To ensure optimum performance of your customer's new RX-1, the following engine break-in procedure should be followed.

1. Begin by running the engine at idle rpm for three, five minute periods, allowing the engine to cool in between (minimum of five minutes). Shut the engine off if the overheat warning indicator becomes lit.

NOTE: Some exhaust smoke may occur during this break-in period, this is normal.

2. At delivery, advise the customer to complete the break-in procedure by following the guidelines below:
 - 0 – 100 miles, avoid prolonged operation above 6,000 rpm
 - 100 – 300 miles, avoid prolonged operation above 8,000 rpm
 - Above 300 miles, the engine can be operated normally.

ADJUSTING REAR SUSPENSION SETTINGS FOR THE CUSTOMER AT DELIVERY

During delivery, one of the most important things you can do to ensure your customer's satisfaction with his/her new RX-1 is to adjust the suspension for his/her weight and riding style. At delivery, take a few minutes to work with the customer to make the following rear suspension adjustments, and ensure maximum ride comfort on the trail.

Predelivery Rear Suspension Adjustments

Full Rate Adjuster (FRA)

Begin by moving the FRA to the following position based on the rider's weight:

FRA position:

- Up to 150 lbs.: Soft (A)
- 150 to 225 lbs.: Medium (B)
- 225 lbs. and up: Hard (C)

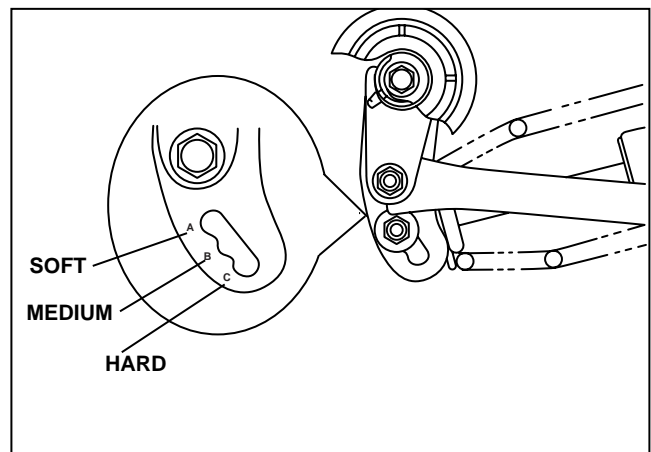

Control Rod Position/Adjustment

After setting the Full Rate Adjuster according to rider weight, check the control rod position with the rider on the machine. Standard suspension settings usually result in the sliding joint positioned near the middle, with approximately equal gap on top and bottom. This provides a good balance of ride comfort, bump capability and handling, but may feel too stiff for some customers. **For maximum ride comfort, the upper gap should be larger than the lower gap at an approximate 75/25 ratio.**

To achieve this, make the following adjustments:

1. First, move the FRA to a stiffer position.
2. If necessary, increase rear spring preload.

Rear Spring Preload/Control Rod Position

Rear spring preload is adjusted according to rider weight, and it affects the control rod position with the rider on the machine.

- Less weight, less preload is required.
- More weight, more preload will be required.

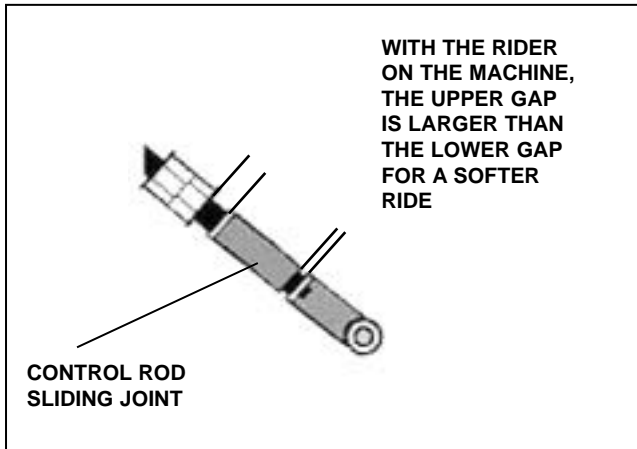

To increase the upper gap, increase the rear spring preload by turning the rear shock spring preload adjuster cam to a higher number position (see illustration below).

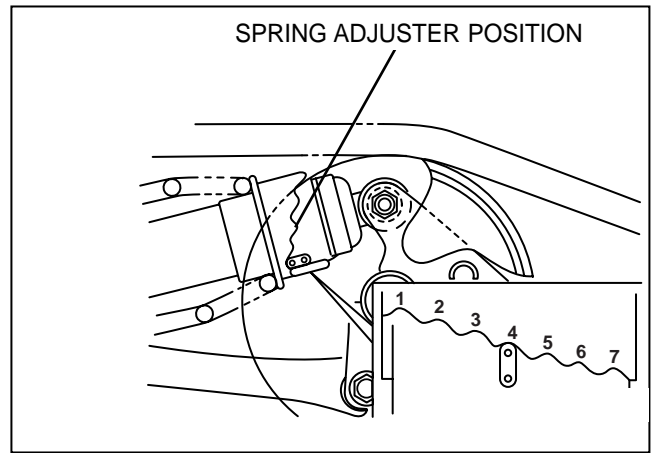

Spring Adjuster Position	1	2	3	4	5	6	7
Preload	Soft			Hard			
<input checked="" type="checkbox"/> Standard (Rear)	4						

The standard rear spring is calibrated for riders weighing from 150 to 250 lbs.

- Most riders under 150 lbs will require a lighter spring.
- Most riders over 250 lbs. will require a heavier spring.